



CREATOR[®]

CREATOR CORPORATION(CHINA)







**Single Core Optical Fiber Transmitter
User's Manual**

V1.0 Version

The meaning of symbols

■ Safety instructions

For your safe and correct use of equipments, we use a lot of symbols on the equipments and in the manuals, demonstrating the risk of body hurt or possible damage to property for the user or others. Indications and their meanings are as follow. Please make sure to correctly understand these instructions before reading the manual.

	<p>This is A level product, which may cause radio interference in the living environment. In this case, users may need to take the feasible measures to get around the interference.</p>
	<p>Remind users that the dangerous voltage without insulation occurring within the equipment may cause people suffer from shock</p>
	<p>CE certification means that the product has reached the directive safety requirements defined by the European Union. Users can be assured about the use of it</p>
	<p>SGS certification means that the product has reached the quality inspection standards proposed by the world's largest SGS.</p>
	<p>This product passed the ISO9001 international quality certification (certification body; TUV Rheinland, Germany).</p>
	<p>Warning; in order to avoid electrical shock, do not open the machine cover, nor is the useless part allowed to be placed in the box. Please contact the qualified service personnel.</p>

■ General information instructions

	<p>It lists the factors leading to the unsuccessful operation or set and the relevant information to pay attention to.</p>
---	--

Important note



Warning

In order to ensure the reliable performance of the equipment and the safety of the user, please observe the following matters during the process of installation, use and maintenance;

The matters needing attention of installation

◆ Please do not use this product in the following places; the place of dust, soot and electric conductivity dust, corrosive gas, combustible gas; the place exposed to high temperature, condensation, wind and rain; the occasion of vibration and impact. Electric shock, fire, wrong operation can lead to damage and deterioration to the product, either;

◆ In processing the screw holes and wiring, make sure that metal scraps and wire head will not fall into the shaft of controller, as it could cause a fire, fault, or incorrect operation;

◆ When the installation work is over, it should be assured there is nothing on the ventilated face, including packaging items like dust paper. Otherwise this may cause a fire, fault, incorrect operation for the cooling is not free;

◆ Should avoid wiring and inserting cable plug in charged state, otherwise it is easy to cause the shock, or electrical damage;

◆ The installation and wiring should be strong and reliable, contact undesirable may lead to false action;

◆ For a serious interference in applications, should choose shield cable as the high frequency signal input or output cable, so as to improve the anti-jamming ability of the system.

Attention in the wiring

◆ Only after cutting down all external power source, can install, wiring operation begin, or it may cause electric shock or equipment damage;

◆ This product grounds by the grounding wires. To avoid electric shocks, grounding wires and the earth must be linked together. Before the connection of input or output terminal, please make sure this product is correctly grounded;

◆ Immediately remove all other things after the wiring installation. Please cover the terminals of the products cover before electrification so as to avoid cause electric shock.

Matters needing attention during operation and maintenance

◆ Please do not touch terminals in a current state, or it may cause a shock, incorrect operation;

◆ Please do cleaning and terminal tighten work after turning off the power supply. These operations can lead to electric shock in a current state;

◆ Please do the connection or dismantle work of the communication signal cable, the expansion module cable or control unit cable after turning off the power supply, or it may cause damage to the equipment, incorrect operation;

◆ Please do not dismantle the equipment, avoid damaging the internal electrical component;

◆ Should be sure to read the manual, fully confirm the safety, only after that can do program changes, commissioning, start and stop operation.

Matters needing attention in discarding product

◆ Electrolytic explosion; the burning of electrolytic capacitor on circuit boards may lead to explosion;

◆ Please collect and process according to the classification, do not put into life garbage;

◆ Please process it as industrial waste, or according to the local environmental protection regulations.

Preface

This manual is only used as user instruction, not for a repair service usage. The functions or related parameters may be changed since the date of issue, please inquire the supplemental information from CREATOR Electronics or local distributors.

The copyright of this manual belongs to CREATOR Electronics. Without permission, no unit or individual shall adopt part or all of its content for commercial use.

The manual is protected by of the Copyright Law of the Peoples Republic of China and other regulations about intellectual property rights. Without written permission shall not be copied or distributed.

Catalog

Chapter 1 Summary.....	1
1.1 Function Characteristics.....	1
1.2 Product Types.....	1
Chapter 2 Controller Description.....	2
2.1 CR-uSF AV 200T Transmitter.....	2
2.1.1 Function Characteristics.....	2
2.1.2 Panel Description.....	2
2.1.3 Connection Diagram.....	3
2.2 CR-Usf D 200T Transmitter.....	3
2.2.1 Function Characteristics.....	3
2.2.2 Panel Description.....	4
2.2.3 Connection Diagram.....	5
2.3 CR-uSF DVI 200R Receiver.....	5
2.3.1 Function Characteristics.....	5
2.3.2 Panel Description.....	5
2.3.3 Connection Diagram.....	6
2.4 CR-uSF HDMI 200R Receiver.....	6
2.4.1 Function Characteristics.....	6
2.4.2 Panel Description.....	6
2.4.3 Connection Diagram.....	7
2.5 CR-uSF VGA 200R Receiver.....	7
2.5.1 Function Characteristics.....	7
2.5.2 Panel Description.....	7
2.5.3 Connection Diagram.....	8
Chapter 3 Technical Parameters.....	9
3.1 CR-uSF AV 200T Parameters.....	9
3.2 CR-uSF HD 200T Parameters.....	12
3.3 CR-uSF DVI 200R Parameters.....	14
3.4 CR-uSF HDMI 200R Parameters.....	16
3.5 CR-uSF VGA 200R Parameters.....	18
Chapter 4 Accessories.....	21
4.1 Infrared Transmitter CR-IR/T.....	21
4.2 Infrared Receiver CR-IR/R.....	21
4.3 3.5mm Headset Connector to DB9 Male Socket Connecting Line.....	21
4.4 3.5mm Headset Connector to DB9 Female Socket Connecting Line.....	21
4.5 DB15 Male Socket to RCA Terminal, SV Terminal Connection Line (VGA to CV video, Y/C video, YPbPr video).....	21

Chapter 1 Summary

CR-uSF AV/HD 200T, CR-uSF VGA/DVI/HDMI 200R are five multimode single core optical fiber transmission products. They are optical transmitter transmitting CV/YC/YPbPr/VGA/DVI/HDMI video and synchronous audio signal, IR signal, RS-232 signal through the single core optical fiber. And they support mixed transmission, remote transmission, high-definition signal transmission and other functions.

This series of products are mainly used in radio and television engineering, multimedia conference hall, large screen display works, television instruction, command and control centers and other occasions.

optical fiber receiver)

- ◆ CR-uSF VGA 200R (VGA video single core optical fiber receiver)

1.1 Function Characteristics

- ◆ Support multiple signal types like CV, YC, YPbPr, VGA, DVI, HDMI, etc.;
- ◆ Support IR, RS-232 signal passing through;
- ◆ Transmission distance is up to 300M, when using the SC optical interface;
- ◆ DC12V external power supply.

1.2 Product Types

- ◆ CR-uSF AV 200T (multi format video single core optical fiber transmitter)
- ◆ CR-uSF HD 200T (HDMI and DVI video single core optical fiber transmitter)
- ◆ CR-uSF DVI 200R (DVI video single core optical fiber receiver)
- ◆ CR-uSF HDMI 200R (HDMI video single core

Chapter 2 Controller Description

2.1 CR-uSF AV 200T

Transmitter

CR-uSF AV 200T is a single core multimode optical fiber transmitter supporting multiple format component video. It can convert CV, Y/C, YPbPr, VGA, DVI, HDMI video signals and Audio signal into optical signal for transmission. It can be used together with the matrix. It supports RS-232 and IR passing through.

2.1.1 Function Characteristics

- ◆ Support for single core multi-mode fiber to transmit CV, Y/C, YPbPr, VGA, DVI, and HDMI signals;
- ◆ With HDMI-Monitor video output monitor function;
- ◆ Support transmission of synchronous Audio signal, IR signal and RS-232 signal;
- ◆ Support the field refresh EDID;
- ◆ Transmission distance is up to 300M.

2.1.2 Panel Description

CR-uSF AV 200T front panel:

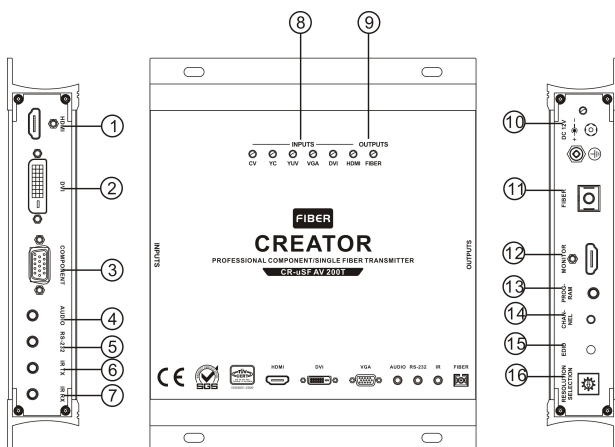

CR-uSF AV 200T rear panel:

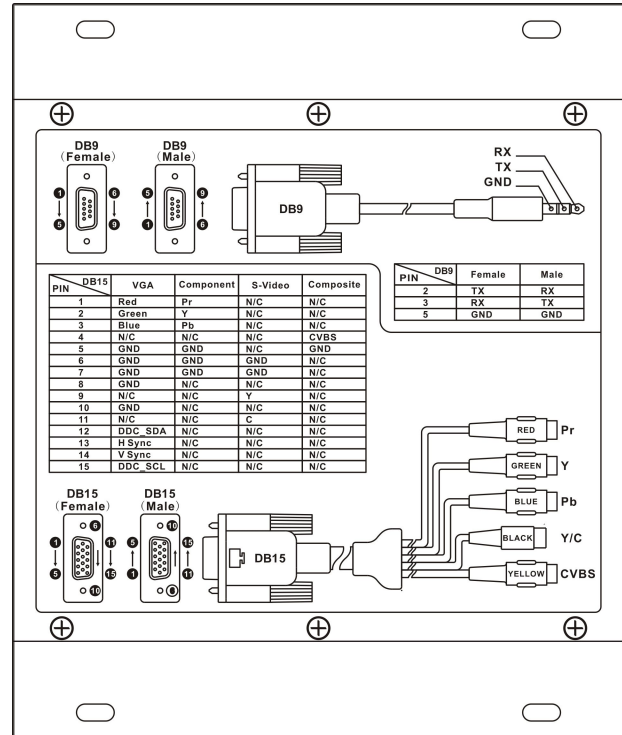

① HDMI—HDMI audio and video input interface

Support one-way HDMI audio and video signal input, using HDMI-A interface, used in PC and other peripheral equipments.

② DVI—DVI video input interface

Support one-way DVI video signal input, using DVI-D interface, used in PC and other peripheral equipments.

③ COMPONENT—Composite video input interface

Support VGA, Y/C, CV, YPbPr video signal input, using DB15 female interface.

④ AUDIO—Audio input interface

Support one-way 3.5mm unbalanced stereo audio input.

⑤ **RS-232**——Serial through interfaces

⑥ **IR TX**——Infrared transmitting interface

Connected with the infrared transmitter to transmit the infrared signal from optical fiber transmission.

⑦ **IR RX**——Infrared receiving interface

Connected with the infrared receiver to receive infrared signal from remote control etc.

⑧ **INPUTS**——Video input indicator

⑨ **OUTPUTS**——Fiber connection indicator

⑩ **DC 12V**——Power and lights

CR-uSF AV 200T power supply and the power indicator light, the indicator lights up when the controller is powered normally.

⑪ **FIBER**——Optical fiber output interface

One-way fiber signal output, used for optical signal transmission.

⑫ **MONITOR**——video monitoring output interface

Support One-way local video monitoring output, using HDMI-A interface, used in display and other peripheral equipments.

⑬ **PROGRAM**——Function configuration interface

Used to configure the parameters for the machine.

⑭ **CHANNEL**——Channel selection button

Press this button to switch different signal inputs.

⑮ **EDID**——EDID read and write keys

Press the key to read and write EDID, used for copy the EDID of display device connected to the local device.

⑯ **RESOLUTION SELECTION**——Resolution selection switcher

This switcher is used to switch the different output resolutions, 10 resolutions are optional.

800 x 600@60Hz

1024 x 768@60Hz

1280 x 720P@60Hz

1280 x 800@60Hz

1280 x 1024@60Hz

1366 x 768@60Hz

1440 x 900@60Hz

1400 x 1050@60Hz

1600 x 900@60Hz

1920 x 1080P@60Hz

2.1.3 Connection Diagram

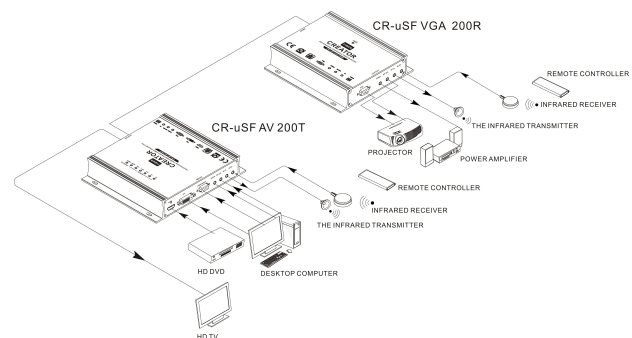

2.2 CR-Usf D 200T Transmitter

CR-uSF HD 200T is a single core multimode optical fiber transmitter supporting high resolution HDMI, DVI signals. It can convert HDMI video signal into optical signal for transmission, and can be used with single core optical fiber transmission receiver or fiber matrix; supports for RS-232 and IR passing through.

2.2.1 Function Characteristics

- ◆ Support single core multi-mode fiber transmission of high resolution of HDMI signal;
- ◆ Support single core multi-mode fiber transmission of high resolution of DVI signal;

- ◆ Support transmission of Audio signal, IR signal and RS-232 signal;
- ◆ Support the field refresh EDID;
- ◆ Transmission distance is up to 300M.

2.2.2 Panel Description

CR-uSF HD 200T front panel:

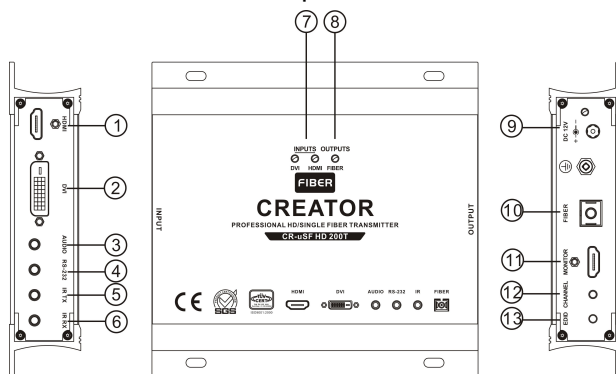

CR-uSF HD 200T rear panel:

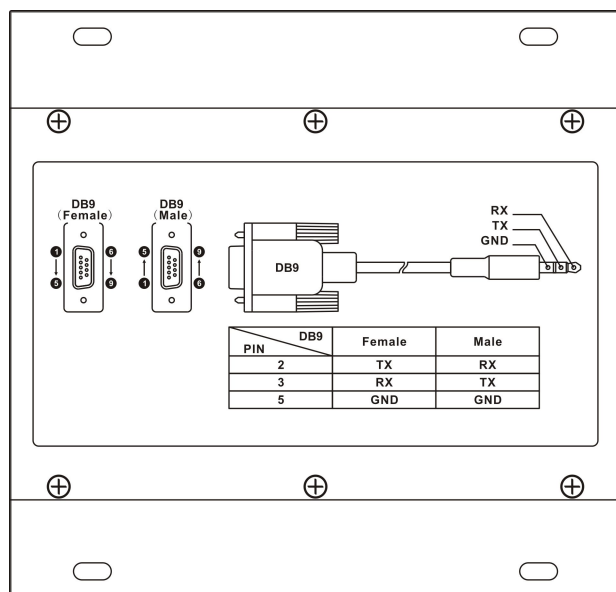

- ① **HDMI**—HDMI audio and video input interface
Support one-way HDMI audio and video signal input, using HDMI-A interface, used in PC and other peripheral equipments.
- ② **DVI**—DVI video input interface

Support one-way DVI video signal input, using DVI-D interface, used in PC and other peripheral equipments.

- ③ **AUDIO**—Audio input interface
Support 1 3.5mm unbalanced stereo audio input.
- ④ **RS-232**—Serial through interfaces
- ⑤ **IR TX**—Infrared transmitting interface
Connect the infrared transmitter to transmit the infrared signal from optical fiber transmission.
- ⑥ **IR RX**—Infrared receiving interface
Connected with the infrared receiver to receive infrared signal from remote control etc..
- ⑦ **INPUTS**—Video input indicator
- ⑧ **OUTPUTS**—fiber connection indicator
- ⑨ **DC 12V**—Power and lights
CR-uSF HD 200T power supply and the power indicator light, the indicator lights up when controller is powered normally.
- ⑩ **FIBER**—Optical fiber output interface
One way fiber signal output, is used for optical signal transmission.
- ⑪ **MONITOR**—Video monitoring output interface
- ⑫ **CHANNEL**—Channel selection button
Press this button to switch different signal inputs.
- ⑬ **EDID**—EDID read and write key
Press the key to read and write EDID, used for copy EDID of local connected display device.

2.2.3 Connection Diagram

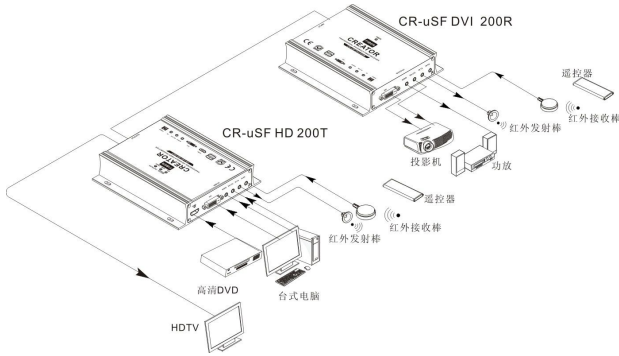

2.3 CR-uSF DVI 200R Receiver

CR-uSF DVI 200R is a single core multimode fiber transmission receiver supporting high resolution DVI signal. It can restore the received optical signal to the HD DVI signal and audio signal, and can be used with CR-uSF HD 200T or fiber matrix; supports for RS-232 and IR passing through.

2.3.1 Function Characteristics

- ◆ support single core multi-mode fiber transmission of high resolution of DVI signal;
- ◆ Support transmission of Audio signal, IR signal and RS-232 signal;
- ◆ Transmission distance is up to 300M.

2.3.2 Panel Description

CR-uSF DVI 200R front panel:

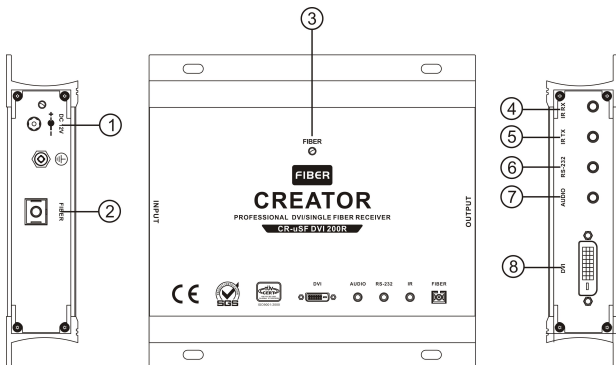

CR-uSF DVI 200R rear panel:

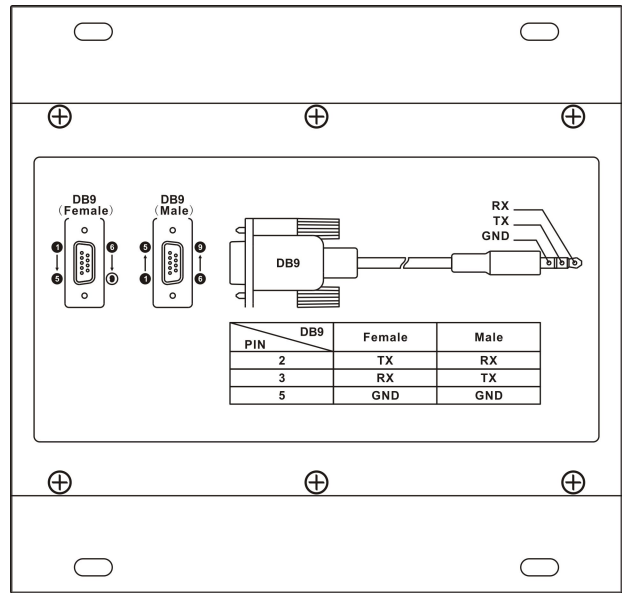

- ① **DC 12V——Power and lights**
CR-uSF DVI 200R power supply and the power indicator light, the indicator lights up when controller is powered normally.
- ② **FIBER——Optical fiber input interface**
One way fiber signal input, is used for optical signal transmission.
- ③ **NPPTS——Fiber connection indicator**
- ④ **IR RX——Infrared receiving interface**
Connected with the infrared receiver, receiving infrared signals of remote control etc.
- ⑤ **IR TX——infrared transmission interface**
Connect the infrared transmitter, transmitting infrared signal from optical fiber transmission.
- ⑥ **RS-232——Serial through interfaces**
- ⑦ **AUDIO——Audio input interface**
Support one way 3.5mm unbalanced stereo audio input.

⑧ DVI——DVI video input interface

Support one way DVI video signal input, using DVI-D interface, used in PC and other peripheral equipments.

2.3.3 Connection Diagram

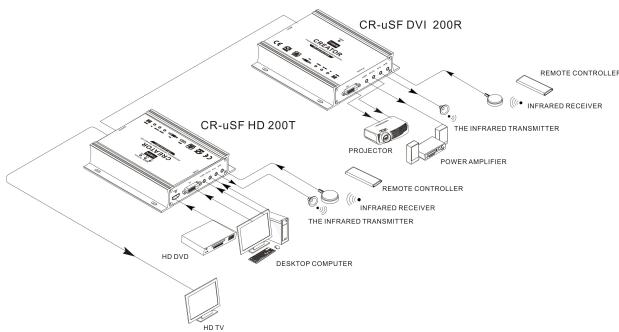

2.4 CR-uSF HDMI 200R

Receiver

CR-uSF HDMI 200R is a single core multimode optical fiber receiver supporting high resolution HDMI signals. It can convert optical fiber video signal into HDMI high-definition signal, and should be used with CR-uSF HD 200T or matrix; supports for RS-232 and IR passing through.

2.4.1 Function Characteristics

- ◆ Support single core multi-mode fiber transmission of high resolution of HDMI signal;
- ◆ Support transmission of Audio signal, IR signal and RS-232 signal;
- ◆ Transmission distance is up to 300M.

2.4.2 Panel Description

CR-uSF HDMI 200R front panel:

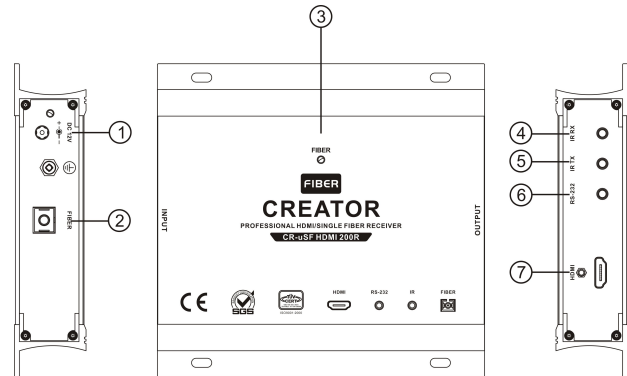

CR-uSF HDMI 200R rear panel :

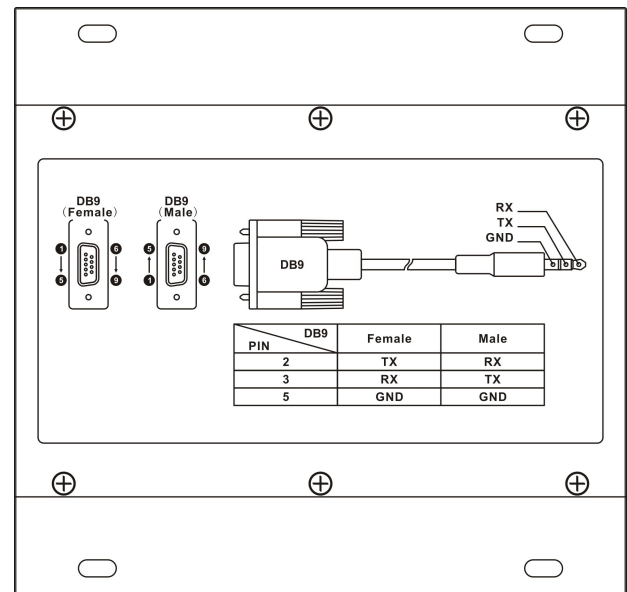

- ① **DC 12V——Power and lights**
CR-uSF HDMI 200R power supply and the power indicator light, the indicator lights up when the controller is powered normally.
- ② **FIBER——Optical fiber input interface**
One way fiber signal input, is used for optical signal transmission.
- ③ **INPUTS——Fiber connection indicator**
- ④ **IR RX——Infrared receiving interface**
Connected with the infrared receiver to receive infrared signal from remote control etc.
- ⑤ **IR TX——Infrared transmitting interface**
Connect the infrared transmitter to transmit the infrared signal from optical fiber transmission.

⑥ RS-232—Serial through interfaces

⑦ HDMI—HDMI audio and video input interface

Support one way HDMI audio and video signal output, using HDMI-A interface, used in PC and other peripheral equipments.

2.4.3 Connection Diagram

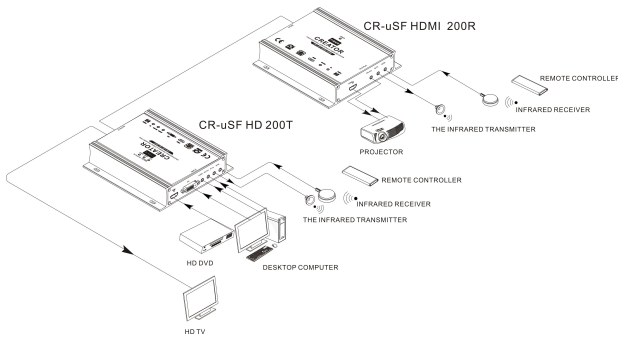

2.5 CR-uSF VGA 200R

Receiver

CR-uSF VGA 200R is a single core multimode fiber transmission receiving terminal supporting high resolution VGA signal. It can restore the received optical signal to VGA signal and audio signal, can be used with CR-uSF HD 200T or optical fiber matrix. It supports RS-232 and IR to pass through.

2.5.1 Function Characteristics

- ◆ Support single core multi-mode fiber transmission of high resolution of VGA signal;
- ◆ Support transmission of Audio signal, IR signal and RS-232 signal;
- ◆ Transmission distance is up to 300M.

2.5.2 Panel Description

CR-uSF VGA 200R front panel:

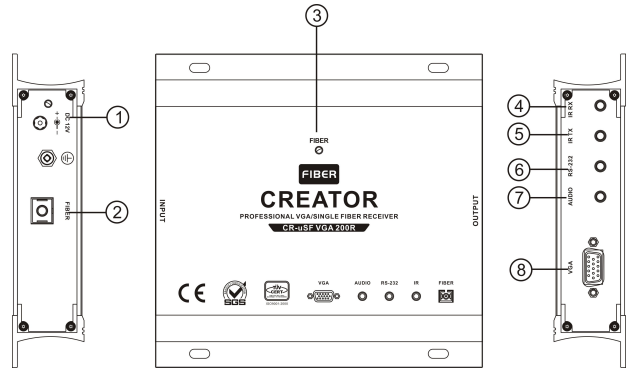

CR-uSF VGA 200R rear panel:

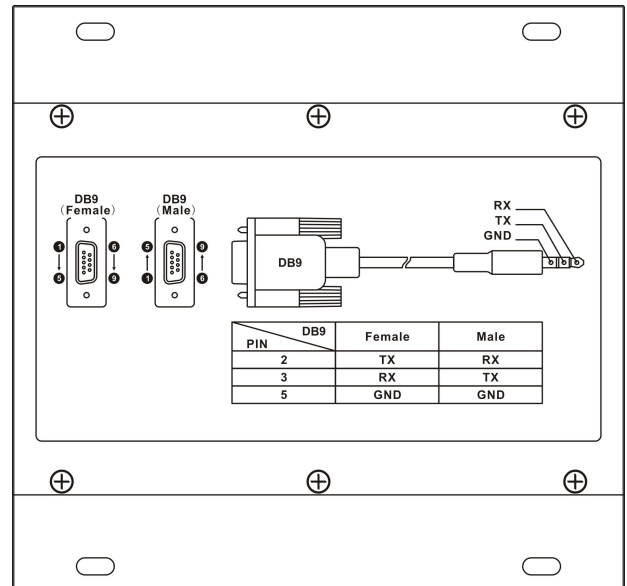

- ① DC 12V—Power and lights
CR-uSF VGA 200R power supply and the power indicator light, the indicator lights up when the controller is powered normally.
- ② FIBER—Optical fiber input interface
One way fiber signal input, is used for optical signal transmission.
- ③ INPUTS—fiber connection indicator
Connect the infrared transmitter to transmit the infrared signal from optical fiber transmission.
- ④ IR RX—Infrared receiving interface
Connected with the infrared receiver to receive

infrared signal from remote control etc.

⑤ **IR TX——Infrared transmitting interface**

Connect the infrared transmitter to transmit the infrared signal from optical fiber transmission.

⑥ **RS-232——Serial through interface**

⑦ **AUDIO——Audio input interface**

Support one way 3.5mm unbalanced stereo audio input.

⑧ **VGA——VGA video output interface**

It supports one way VGA video signal output, using DB-15 interface, used in PC and other peripheral equipments.

2.5.3 Connection Diagram

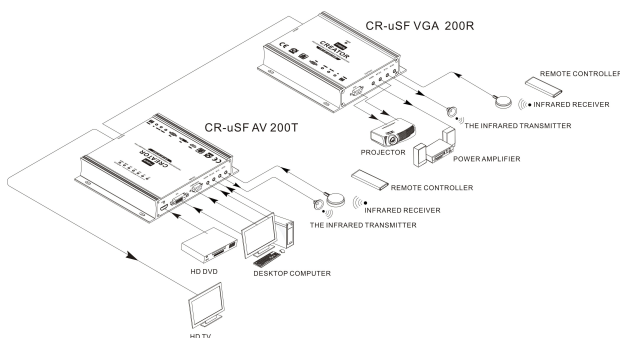

Chapter 3 Technical Parameters

3.1 CR-uSF AV 200T Parameters

Specifications Model	CR-uSF AV 200T			
Analog video input				
Interface	HD-15 Interface			
Signal Type	Composite video CV	Y/C video	Component videoYPbPr	VGA video
Gain	0dB	0dB	0 dB	0 dB
Bandwidth	150MHz @ -3dB	150MHz @ -3dB	350MHz @ -3dB	380 MHz
Differential phase error	0.1°,3.58-4.43 MHz	0.1°,3.58-4.43 MHz	0.1°,3.58-4.43 MHz	
Differential gain error	0.1% , 3.58-4.43 MHz	0.1% , 3.58-4.43 MHz	0.1% , 3.58-4.43 MHz	
Signal Strength	1V p-p ; Composite video (CVBS)	1V p-p: S VIDEO(Y/C)	1V p-p ;(Y in component video) 0.3Vp-p; (PbPr/CbCr in component video)	0.63V p-p to 0.9 V p-p
Minimum / maximum level	Analog signal ; -2V/+2V	Analog signal ; -2V/+2V	Analog signal ; -2V/+2V	RGB signal;0V/1.0V HV signal:0V/5.0V
Input impedance	75 Ω	75 Ω	75Ω	75Ω
Echo Loss	<-30dB@5MHz z	<-30dB@5MHz	<-30dB@5MHz	<-30dB@5MHz
DVI video input				
Supported protocols	DVI1.0,HDMI1.3a,HDCP1.3			
PIXEL Bandwidth	PIXEL 165MHz , full digital			
Interface bandwidth	2.25Gbps,full digital(a total of 6.75Gbps. each color is 2.25Gbps)			
Maximum support resolution	PC 1920x1200@60_24bit Color depth HDTV 1920x1080P@60_36bit Color depth			
Clock Jitter	<0.15 T bit			
Rise time	<0.3Tbit (20%--80%)			
Fall time	<0.3Tbit (20%--80%)			
Signal Type	DVI-D/ HDMI full digital T.M.D.S. signal in DVI 1.0 / HDMI 1.3a specification			
Interface	DVI-D Interface			
Signal Strength	T.M.D.S. 3.3V p-p			

Specifications Model	CR-uSF AV 200T
Minimum / maximum level	T.M.D.S. 2.9V/3.3V
Input impedance	50 Ω
Input EDID	Using the default EDID, (support terminal EDID mapping to input)
Maximum DC offset error	+/-15mV
The recommended maximum input distance	Less than 10 meters, when the resolution is 1920x1080p@60 (recommended the use of certified HDMI special wire, as Molex TM wire)
HDMI video input	
Supported protocols	DVI1.0,HDMI1.3a,HDCP1.3
PIXEL bandwidth	The pixel bandwidth 165MHz , full digital
Interface bandwidth	2.25Gbps, full digital (a total of 6.75Gbps. each color is 2.25Gbps)
Maximum support resolution	PC 1920x1200@60_24bit Color depth HDTV 1920x1080P@60_36bit Color depth
Clock Jitter	<0.15 Tbit
Rise time	<0.3Tbit (20%--80%)
Fall time	<0.3Tbit (20%--80%)
Signal Type	DVI-D/ HDMI full digital T.M.D.S. signal in DVI 1.0 / HDMI 1.3a specification
Interface	HDMI-A Interface (Type A connector)
Signal Strength	T.M.D.S. 3.3V p-p
Minimum / maximum level	T.M.D.S. 2.9V/3.3V
Impedance	50 Ω
Input EDID	Using the default EDID, (support terminal EDID mapping to input)
Maximum DC offset error	+/-15mV
The recommended maximum input distance	Less than 10 meters, when the resolution is 1920x1080p@60 (recommended the use of certified HDMI special wire, as Molex TM wire)
Sound signal	
Input/output Interface	3.5mm unbalanced stereo audio input
Gain	0 dB
Frequency response	20 Hz ~ 20 kHz,
Total harmonic distortion + noise	0.01% @ 1 kHz (Under rated voltage)
The signal-to-noise ratio (S/N)	>80dB at Vin=0 V
Stereo separation	>80dB @ 1 kHz

Specifications Model	CR-uSF AV 200T
Common mode rejection ratio(CMRR)	>75dB @; 20 Hz ~ 20 kHz
Signal Type	Stereo (Unbalanced connection)
Impedance	Input:>10 kΩ(balanced or unbalanced connection) Output:50Ω (unbalanced connection)
Maximum input level	+19.5dBu, (balanced or unbalanced connection)
Gain error	±0.1dB @20 Hz ~ 20 kHz
IR INFRARED	
Interface	Input: 3.5mm unbalanced vertical stereo audio socket Output:3.5mm unbalanced vertical stereo audio socket
Signal Type	Input; digital Output; digital
Output level type	PLL level
Wavelength	850nm
The carrier frequency of input level	38KHz
RS-232	
Interface	RS-232, 3.5mm unbalanced vertical stereo audio socket
Signal Type	Digital
Level type	RS-232 level
Signal direction	Bi-direction communication
Baud rate	Min;4800bps Max;115200bps
Data bits	8
Stop bit	1
Correction bits	None
Flow control	None
Level delay	500 ns
Peak	+/-15V
Output	
Fiber output interface	SC connector
Fiber type	Multimode / Single Mode(Optional)
Wavelength	Multimode 850nm / Single Mode; 1310 –1620nm(Optional)
Interface bandwidth	Positive; 6.25Gbps, reverse:3.125Gbps
Clock Jitter	<0.15T bit
Rise time	<0.3Tbit (20%--80%)
Fall time	<0.3Tbit (20%--80%)
The recommended maximum input distance	OM3 multimode fiber; less than 300 meters, when the resolution is 1920x1080p@60
Other specifications	
Power supply	Power adaptor, 12VDC/2A

Specifications Model	CR-uSF AV 200T
Power consumption	MAX 5W
Temperature	Storage, use temperature; -20°~ +70°C
Humidity	Storage, use humidity;10% ~90%
Dimension	162(L)X 155(W)X 35mm(H)
Weight	720g
Mean time between failures	30,000 hours
Warranty	1 year free warranty, life-long maintenance

3.2 CR-uSF HD 200T Parameters

Specifications Model	CR-uSF HD 200T
DVI video input	
Supported protocols	DVI1.0,HDMI1.3a,HDCP1.3
PIXEL bandwidth	The pixel bandwidth165MHz , full digital
Interface bandwidth	2.25Gbps, full digital (a total of 6.75Gbps. each color is 2.25Gbps)
Maximum support resolution	PC 1920x1200@60_24bit Color depth HDTV 1920x1080P@60_36bit Color depth
Clock Jitter	<0.15T bit
Rise time	<0.3Tbit (20%--80%)
Fall time	<0.3Tbit (20%--80%)
Signal Type	DVI-D/ HDMI full digital T.M.D.S. signal in DVI 1.0 / HDMI 1.3a specification
Interface	DVI-D Interface
Signal Strength	T.M.D.S. 3.3V p-p
Minimum / maximum level	T.M.D.S. 2.9V/3.3V
Input impedance	50 Ω
Input EDID	Using the default EDID, (support terminal EDID mapping to input)
Maximum DC offset error	+/-15mV
The recommended maximum input distance	Less than 10 meters, when the resolution is 1920x1080p@60 (recommended the use of certified HDMI special wire, as Molex TM wire)
HDMI video input	
Supported protocols	DVI1.0,HDMI1.3a,HDCP1.3
PIXEL bandwidth	The pixel bandwidth165MHz , full digital
Interface bandwidth	2.25Gbps, full digital (a total of 6.75Gbps. each color is 2.25Gbps)
Maximum support resolution	PC 1920x1200@60_24bit Color depth HDTV 1920x1080P@60_36bit Color depth

Specifications Model	CR-uSF HD 200T
Clock Jitter	<0.15T bit
Rise time	<0.3Tbit (20%--80%)
Fall time	<0.3Tbit (20%--80%)
Signal Type	DVI-D/ HDMI full digital T.M.D.S. signal in DVI 1.0 / HDMI 1.3a specification
Interface	HDMI-A Interface
Signal Strength	T.M.D.S. 3.3V p-p
Minimum / maximum level	T.M.D.S. 2.9V/3.3V
Impedance	50 Ω
Input EDID	Using the default EDID, (support terminal EDID mapping to input)
Maximum DC offset error	+/-15mV
The recommended maximum input distance	Less than 10 meters, when the resolution is 1920x1080p@60 (recommended the use of certified HDMI special wire, as Molex TM wire)
Sound signal	
Input / output interface	3.5mm unbalanced stereo audio input
Gain	0 dB
Frequency response	20 Hz ~ 20 kHz,
Total harmonic distortion + noise	0.01% @ 1 kHz (Under rated voltage)
The signal-to-noise ratio (S/N)	>80dB at Vin=0 V
Stereo separation	>80dB @ 1 kHz
Common mode rejection ratio(CMRR)	>75dB @; 20 Hz ~ 20 kHz
Signal Type	Stereo (Unbalanced connection)
Impedance	Input:>10 k Ω (Balanced or unbalanced connection) Output:50 Ω (unbalanced connection)
Maximum input level	+19.5dBu, (Balanced or unbalanced connection)
Gain error	\pm 0.1dB @20 Hz ~ 20 kHz
IR INFRARED	
Interface	Input: 3.5mm unbalanced vertical stereo audio socket / Output:3.5mm unbalanced vertical stereo audio socket
Signal Type	Input; digital Output:digital
Output level type	PLL level
Wavelength	850nm
The carrier frequency of input level	38KHz
RS-232	

Specifications Model	CR-uSF HD 200T	
Interface	RS-232, 3.5mm unbalanced vertical stereo audio socket	
Signal Type	digital	
Level type	RS-232 level	
Signal direction	Bi-direction communication	
Baud rate	Min;4800bps	Max;115200bps
Data bits	8	
Stop bit	1	
Correction bits	None	
Flow control	None	
Level delay	500 ns	
Peak	+/-15V	
Output		
Fiber output interface	SC connector	
Fiber type	Multimode / Single Mode(Optional)	
Wavelength	Multimode 850nm / Single Mode; 1310 –1620nm(Optional)	
Interface bandwidth	Positive; 6.25Gbps, reverse:3.125Gbps	
Clock Jitter	<0.15Tbit	
Rise time	<0.3Tbit (20%--80%)	
Fall time	<0.3Tbit (20%--80%)	
The recommended maximum input distance	OM3 multimode fiber; less than 300 meters, when the resolution is 1920x1080p@60	
Other specifications		
Power supply	Power adaptor, 12VDC/2A	
Power consumption	MAX 5W	
Temperature	Storage, use temperature; -20°~ +70°C	
Humidity	Storage, use humidity; 10% ~90%	
Dimension	162(L)X 155(W)X 35mm(H)	
Weight	620g	
Mean time between failures	30,000 hours	
Warranty	1 year free warranty, life-long maintenance	

3.3 CR-uSF DVI 200R Parameters

Specifications Model	CR-uSF DVI 200R	
DVI video output		
Supported protocols	DVI1.0, HDMI1.3a, HDCP1.3	
PIXEL bandwidth	The pixel bandwidth 165MHz , full digital	
Interface bandwidth	2.25Gbps, full digital (a total of 6.75Gbps. each color is 2.25Gbps)	

Specifications Model	CR-uSF DVI 200R
Maximum support resolution	PC 1920x1200@60_24bit Color depth HDTV 1920x1080P@60_36bit Color depth
Clock Jitter	<0.15Tbit
Rise time	<0.3Tbit (20%--80%)
Fall time	<0.3Tbit (20%--80%)
Signal Type	DVI-D/ HDMI full digital T.M.D.S. signal in DVI 1.0 / HDMI 1.3a specification
Interface	DVI-D Interface
Signal Strength	T.M.D.S. 3.3V p-p
Minimum / maximum level	T.M.D.S. 2.9V/3.3V
Output impedance	50 Ω
Maximum DC offset error	+/-15mV
The recommended maximum output distance	Less than 10 meters, when the resolution is 1920x1080p@60 (recommended the use of certified HDMI special wire, as Molex TM wire)
Sound signal	
Input interface	3.5mm unbalanced stereo audio input
Gain	0 dB
Frequency response	20 Hz ~ 20 kHz,
Total harmonic distortion + noise	0.01% @ 1 kHz (Under rated voltage)
The signal-to-noise ratio (S/N)	>80dB at Vin=0 V
Stereo separation	>80dB @ 1 kHz
Common mode rejection ratio(CMRR)	>75dB @; 20 Hz ~ 20 kHz
Signal Type	Stereo (Unbalanced connection)
Impedance	Input:>10 k Ω (Balanced or unbalanced connection) Output:50 Ω (unbalanced connection)
The maximum output level	+19.5dBu, (Balanced or unbalanced connection)
Gain error	\pm 0.1dB @20 Hz ~ 20 kHz
IR INFRARED	
Interface	Input,: 3.5mm unbalanced vertical stereo audio socket Output:3.5mm unbalanced vertical stereo audio socket
Signal Type	Input; digital Output:digital
Output level type	PLL level
Wavelength	850nm

Specifications Model	CR-uSF DVI 200R	
The carrier frequency of input level	38KHz	
RS-232		
Interface	RS-232, 3.5mm unbalanced vertical stereo audio socket	
Signal Type	digital	
Level type	RS-232 level	
Signal direction	Bi-direction communication	
Baud rate	Min;4800bps	Max;115200bps
Data bits	8	
Stop bit	1	
Correction bits	None	
Flow control	None	
Level delay	500 ns	
Peak	+/-15V	
Input		
Fiber output interface	SC connector	
Fiber type	Multimode / Single Mode(Optional)	
Wavelength	Multimode; 850nm / Single Mode; 1310 –1620nm(Optional)	
Interface bandwidth	Positive; 6.25Gbps, reverse:3.125Gbps	
Clock Jitter	<0.15T bit	
Rise time	<0.3Tbit (20%--80%)	
Fall time	<0.3Tbit (20%--80%)	
The recommended maximum input distance	OM3 multimode fiber; less than 300 meters, when the resolution is 1920x1080p@60	
Other specifications		
Power supply	Power adaptor,12VDC/2A	
Power consumption	MAX 5W	
Temperature	Storage, use temperature; -20°~ +70°C	
Humidity	Storage, use humidity;10% ~90%	
Dimension	162(L)X 155(W)X 35mm(H)	
Weight	600g	
Mean time between failures	30,000 hours	
Warranty	1 year free warranty, life-long maintenance	

3.4 CR-uSF HDMI 200R Parameters

Specifications Model	CR-uSF HDMI 200R	
HDMI video output		
Supported protocols	DVI1.0, HDMI1.3a, HDCP1.3	

Specifications Model	CR-uSF HDMI 200R
PIXEL bandwidth	The pixel bandwidth 165MHz , full digital
Interface bandwidth	2.25Gbps, full digital (a total of 6.75Gbps. each color is 2.25Gbps)
Maximum support resolution	PC 1920x1200@60_24bit Color depth HDTV 1920x1080P@60_36bit Color depth
Clock Jitter	<0.15Tbit
Rise time	<0.3Tbit (20%--80%)
Fall time	<0.3Tbit (20%--80%)
Signal Type	DVI-D/ HDMI full digital T.M.D.S. signal in DVI 1.0 / HDMI 1.3a specification
Interface	HDMI-A Interface
Signal Strength	T.M.D.S. 3.3V p-p
Minimum / maximum level	T.M.D.S. 2.9V/3.3V
Impedance	50 Ω
Maximum DC offset error	+/-15mV
The recommended maximum output distance	Less than 10 meters, when the resolution is 1920x1080p@60 (recommended the use of certified HDMI special wire, as Molex TM wire)
IR INFRARED	
Interface	Input: 3.5mm unbalanced vertical stereo audio socket Output:3.5mm unbalanced vertical stereo audio socket
Signal Type	Input; digital Output:digital
Output level type	PLL level
Wavelength	850nm
The carrier frequency of input level	38KHz
RS-232	
Interface	RS-232, 3.5mm unbalanced vertical stereo audio socket
Signal Type	Digital
Level type	RS-232 level
Signal direction	Bi-direction communication
Baud rate	Min;4800bps Max;115200bps
Data bits	8
Stop bit	1
Correction bits	None
Flow control	None
Level delay	500 ns
Peak	+/-15V
Input	

Specifications Model	CR-uSF HDMI 200R
Fiber output interface	SC connector
Fiber type	Multimode / Single Mode(Optional)
Wavelength	Multimode; 850nm / Single Mode; 1310 –1620nm(Optional)
Interface bandwidth	Positive; 6.25Gbps, reverse:3.125Gbps
Clock Jitter	<0.15T bit
Rise time	<0.3Tbit (20%--80%)
Fall time	<0.3Tbit (20%--80%)
The recommended maximum input distance	OM3 multimode fiber; less than 300 meters,when the resolution is 1920x1080p@60 Single-mode fiber; less than 10km,when the resolution is 1920x1080p@60
Other specifications	
Power supply	Power adaptor,12VDC/2A
Power consumption	MAX 5W
Temperature	Storage, use temperature; -20°~ +70°C
Humidity	Storage, use humidity;10% ~90%
Dimension	162(L)X 155(W)X 35mm(H)
Weight	600g
Mean time between failures	30,000 hours
Warranty	1 year free warranty, life-long maintenance

3.5 CR-uSF VGA 200R Parameters

Specifications Model	CR-uSF VGA 200R
VGA video output	
Gain	0 dB
Bandwidth	380 MHz
Signal Type	VGA
Interface	15-pinDB female interface
Signal Strength	0.7V p-p
Impedance	75 Ω
Echo Loss	<-30dB@5MHz
DC compensation	Maximum ±5mV
VGA synchronous signal	
Input/output Signal Type	RGBHV, RGBS, RGsB , RsGsBs,
Maximum transmission delay	Horizontal;90ns Vertical;160ns
Maximum rise / fall time	4ns

Specifications Model	CR-uSF VGA 200R
Polarity	Positive or negative (completely consistent with the input)
Sound signal	
Input interface	3.5mm unbalanced stereo audio input
Gain	0 dB
Frequency response	20 Hz ~ 20 kHz,
Total harmonic distortion + noise	0.01% @ 1 kHz (Under rated voltage)
The signal-to-noise ratio (S/N)	>80dB at Vin=0 V
Stereo separation	>80dB @ 1 kHz
Common mode rejection ratio(CMRR)	>75dB @; 20 Hz ~ 20 kHz
Signal Type	Stereo (unbalanced connection)
Impedance	Input:>10 kΩ(balanced or unbalanced connection) Output:50Ω (unbalanced connection)
The maximum output level	+19.5dBu, (Balanced or unbalanced connection)
Gain error	±0.1dB @20 Hz ~ 20 kHz
IR INFRARED	
Interface	Input: 3.5mm unbalanced vertical stereo audio socket Output:3.5mm unbalanced vertical stereo audio socket
Signal Type	Input; digital Output:digital
Output level type	PLL level
Wavelength	850nm
The carrier frequency of input level	38KHz
RS-232	
Interface	RS-232, 3.5mm unbalanced vertical stereo audio socket
Signal Type	Digital
Level type	RS-232 level
Signal direction	Bi-direction communication
Baud rate	Min; 4800bps Max;115200bps
Data bits	8
Stop bit	1
Correction bits	None
Flow control	None
Level delay	500 ns
Peak	+/-15V
Input	

Specifications Model	CR-uSF VGA 200R
Fiber output interface	SC connector
Fiber type	Multimode / Single Mode(Optional)
Wavelength	Multimode; 850nm / Single Mode; 1310 –1620nm(Optional)
Interface bandwidth	Positive; 6.25Gbps, reverse:3.125Gbps
Clock Jitter	<0.15T bit
Rise time	<0.3Tbit (20%--80%)
Fall time	<0.3Tbit (20%--80%)
The recommended maximum input distance	OM3 multimode fiber; less than 300 meters, when the resolution is 1920x1080p@60
Other specifications	
Power supply	Power adaptor,12VDC/2A
Power consumption	MAX 5W
Temperature	Storage, use temperature; -20°~ +70°C
Humidity	Storage, use humidity;10% ~90%
Dimension	162(L)X 155(W)X 35mm(H)
Weight	600g
Mean time between failures	30000 hours
Warranty	1 year free warranty, life-long maintenance

Chapter 4 Accessories

4.1 Infrared Transmitter

CR-IR/T

The infrared transmitter CR-IR / T is used to transmit infrared signals to the infrared receiver, infrared emission frequency ranging from 20 KHz to 100KHz.

CR-IR/T

Dimensions;

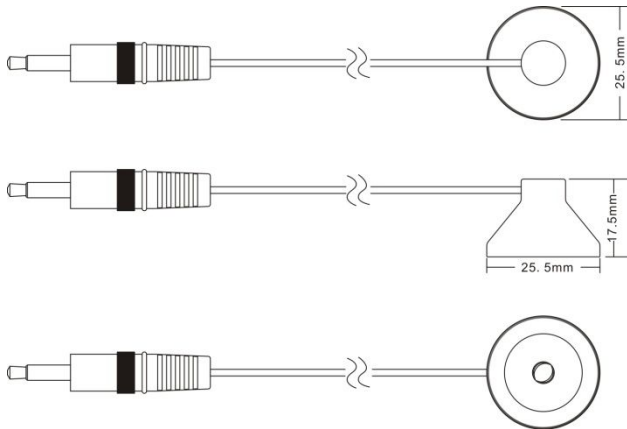

4.2 Infrared Receiver CR-IR/R

Infrared receiver CR-IR / R is for receiving the infrared signal to the infrared device, infrared receiver frequency is 38KHz.

CR-IR/R Dimensions:

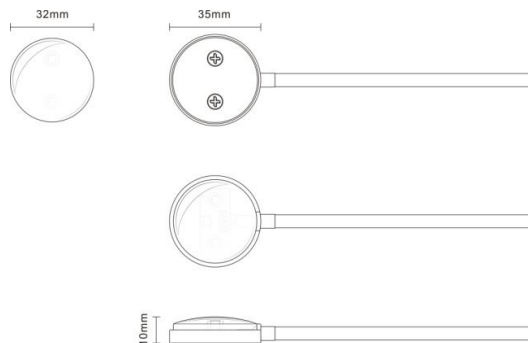

4.3 3.5mm Headset Connector to DB9 Male Socket Connecting Line



4.4 3.5mm Headset Connector to DB9 Female Socket Connecting Line



4.5 DB15 Male Socket to RCA Terminal, SV Terminal Connection Line (VGA to CV video, Y/C video, YPbPr video)



CREATOR CORPORATION(CHINA)
Copyright by CREATOR

Last Revision:08/2013